

**Dimensions**

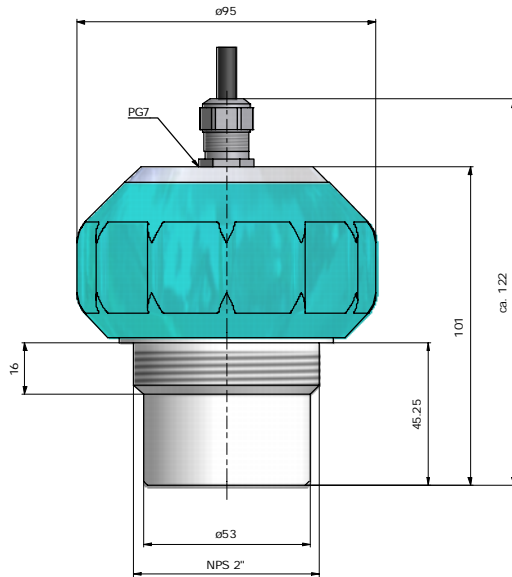

Figure 1: Ultrasonic Level Transducer

**Description and application**

The MPULxx is an ultrasonic transducer used for determining and transmitting liquid levels from within open or enclosed vessels. The compact integral assembly includes; the level sensing transducer, temperature compensation transducer to ensure accurate level indications throughout the temperature range and electronic circuitry, in a totally encapsulated and virtually chemically inert casing. The casing consists of a ABS electronics housing and a Tefzel™ nose part. LED's are fitted to the MPULxx casing to verify that the assembly is functioning properly.

**Principle of operation**

Short controlled ultrasonic pulses emanating from the transducer are aimed at a target surface. After filtering-out any noise present, the time taken for the reflected pulses to strike the sensor surface are converted to linear measurements and conveyed to the remote indicator/recorder as a current value.

**Setting-up the transducer**

The transducer is set-up for the minimum level ZERO, and the maximum level SPAN, by means of momentarily contacting the respective areas marked SPAN and ZERO on the surface of the assembly with the magnetic key supplied.

**Precautions**

The use of 2 conductor shielded pair cable is recommended to eliminate noise emanating from induced voltages.

The transducer must be handled with care to prevent damage to the transducer which is situated near the front surface of the nose.

## Technical Data

Range:	250 mm / 9.8 in. to 6 m / 19.7 ft. in liquids at 23°C / 73.4°F
Current output:	4 – 20 mA span directly or inversely proportional
Accuracy:	Better or equal to +/- 0.25% of maximum span at constant temperature
Resolution:	3 mm / 0.12 in.
Point setting:	By magnetic key, non-volatile storage
Status indication:	Two visible LED's
Fault current:	22 mA
Loop load:	$R_{\max} = \frac{V_{\text{supply}} - 17}{22} k\Omega$
Beam angle:	7° at -3 dB boundary
Frequency:	55 kHz to 60 kHz
Storage temperature:	-40°C / -40°F to 80°C / 176°F
Operating temperature:	-20°C / -4°F to 60°C / 140°F, please note that transducer has internal temperature compensation.
Enclosure rating:	IP68 submersible
Mass (approx.):	1 kg / 2.2 lb including integral 7 m / 23 ft. cable
Dimensions:	Diameter: 95 mm / 3.74 in. Overall length: 122 mm / 4.80 in.
Housing Details:	UV Resistant ABS housing and Tefzel™ Nose.
Mounting:	Suspended from cable or mounted in 2" NPS / BSP Flange.
Supply voltage:	17V to 30V DC (max.) 24V DC Typical Operating Voltage
Protection:	Protected against reverse polarity and voltage surges.
Certifications:	EEx ia IIC T6 (Tamb=-20°C to 60°C) IA No: SABS S/S828 X U <sub>i</sub> =28V I <sub>i</sub> =93 P <sub>i</sub> =0.65W L <sub>i</sub> =4uH C <sub>i</sub> =100nF  IEC61326-1 / IEC801-3 / EN55011

## LED indication

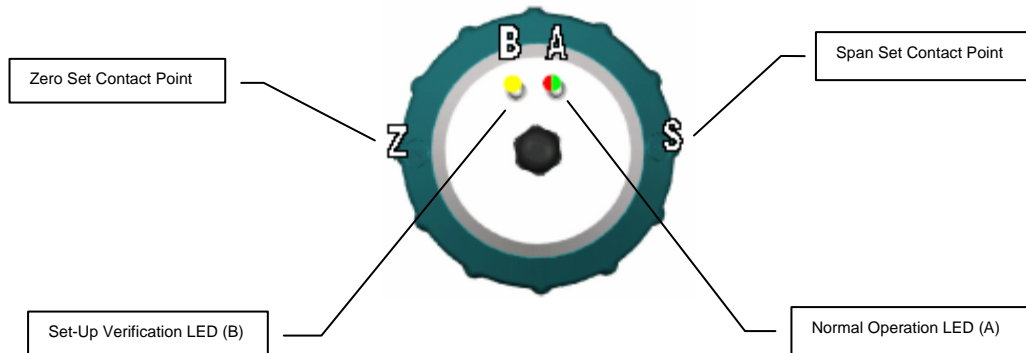

LED A: GREEN is ON and RED is FLASHING

The transducer is functioning satisfactorily within the set range.

---

LED A: RED is ON and GREEN is FLASHING

In this condition: If LED B is also on, a weak echo is received. If LED B is off, the transducer sees an echo outside the set range.

If this condition persists, the transducer will set the default current after approximately sixty seconds.

---

LED B: ON during operation

The transducer is re-evaluating echo conditions.

## Installation

### Mounting the transducer

There are three methods of mounting:

- Suspended from the cable.
- Screwed into a pipe coupling threaded 2 inch NPS. It is important that only the correct thread is mated with the transducer otherwise the assembly will be damaged.
- Screwed into a flange with a 2 inch NPS thread and then bolted to a mating flange on the vessel. The use of a rubber o-ring is recommended.

### Precautions when mounting

- To prevent spurious echo signals, the transducer must be mounted perpendicular to the surface being monitored.
- It is strongly recommended that the transducer is mounted off the centre axis; the axes of the vessel and the transducer must therefore not coincide. To eliminate echoes emanating from the wall, the axis of the transducer must be far enough from the vessel wall.
- The transducer must be mounted at least **250 mm** above the maximum anticipated liquid level.

### Electrical installation

- Please refer to the connection diagram for the wiring details; always ensure that shield is connected to a proper ground or earth point.
- Make sure that the transducer always receives an absolute minimum of 17Volts. Recorders and controllers can take their share of the available voltage; always check how much voltage they are taking in the loop.
- Make sure appropriate cabling is used. From the cable's typical resistance and the length of the cable in the installation, one can calculate how much voltage is used in the loop by the cable.
- The connection between the transducer and the customer supplied indicator/recorder is effected by means of a 2 conductor shielded pair cable. The maximum permissible cable distance is 1km / 3280ft.

### Connection diagram

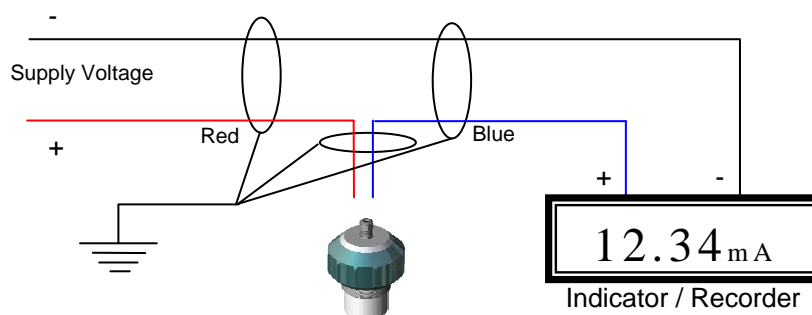

Installation Details

Level Measurement

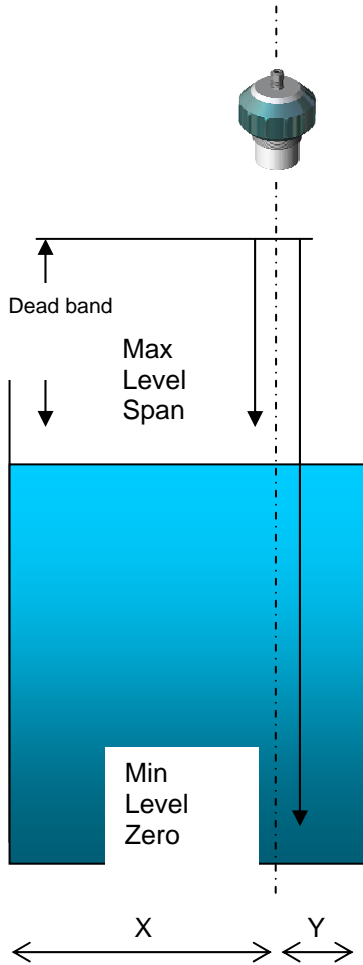

Distance Measurement

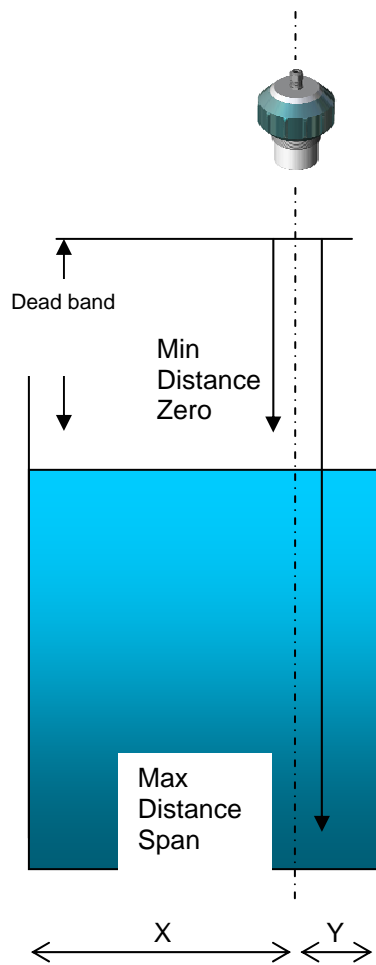

Preferred installation is where  $X \neq Y$

Some tolerance on the end-points can be expected due to rapid temperature fluctuations, always program the controller to switch pumps / valves before the absolute limits are reached. Alternatively set the instrument to operate outside the tank's physical limits.

Please note that the transducer can never measure less than 250 mm.

## Setting-up the transducer

Touching a magnet to the circled SPAN and ZERO areas on the housing sets the transducer operating distances. The transducer has internal non-volatile storage and even when power is removed, will always remember the last set reference levels.

*Note: Prolonged contact of the magnetic key on the SPAN or ZERO targets should be avoided.*

### A. In situ procedure for level

#### Zero level (ZERO - 4mA):

- Aim instrument at the correct target. If this is done on a tank, ensure that tank is at the right minimum level.
- Contact ZERO (on housing) with the magnetic key until LED B lights to indicate that set-up mode has been entered, remove key.
- LED B turns off to indicate that the minimum level has been accepted; this process may take up to 10 seconds. Subsequently, LED A continues with Green On and Red flashes.
- If LED B does not turn off during setup the measuring conditions may be insufficient. (See Trouble Shooting assistance)
- The new level is saved only at the point where LED B turns off. When setting the level, do not move the instrument while LED B is on.

#### Maximum level (SPAN - 20mA):

This procedure is identical to the Zero Level operation except that the SPAN contact is used and the level is on maximum.

### B. In situ procedure for distance

#### Minimum distance (ZERO - 4mA):

- Aim instrument at the correct target. If this is done on a tank, ensure that tank is at the right maximum level.
- Contact ZERO (on housing) with the magnetic key until LED B lights to indicate that set-up mode has been entered, remove key.
- LED B turns off to indicate that the minimum distance has been accepted; this process may take up to 10 seconds. Subsequently, LED A continues with Green On and Red flashes.
- If LED B does not turn off during setup the measuring conditions may be insufficient. (See Trouble Shooting assistance)
- The new level is saved only at the point where LED B turns off. When setting the level, do not move the instrument while LED B is on.

#### Maximum distance (SPAN - 20mA):

This procedure is identical to the Zero Level operation except that the SPAN contact is used and the level is on minimum.

### C. Setting-up in the workshop

Instead of setting up the transducer in situ, it might be more convenient to do this in the workshop: Point the nose of the transducer at walls which are at horizontal distances equivalent to the maximum level SPAN and minimum level ZERO, respectively. Follow the in situ method described above.

## Trouble shooting assistance

### 1. Instrument lights do not switch on:

- Check that polarity of supply is correct, Red wire for Positive, Blue wire for negative.
- Check the voltage across the instrument; it must be greater than 17V and less than 30V.
- Check that the circuit is complete; insert a meter to check if a current is present. The current should not be greater than 30mA and should at least be 3.8mA.

### 2. Instrument switches ON but indicates RED LED ON with GREEN Flashes:

- Target may be out of range; ensure that the MPUL06 is pointing at the right surface.
- Ensure that the instrument is set for the correct range; use SPAN and ZERO to set Span and Zero. Note: Do not set Span and Zero at the same distance.
- Ensure that the instrument is audibly “clicking”, if unsure feel the nose front for vibration. This should occur at a frequency of between 2 to 4 clicks per second.

### 3. With the instrument calibrated correctly and a theoretical current value calculated, it indicates an unexpected current value:

- Check the voltage across the instrument; it must be above 17V and below 30V.
- In the case of a closed tank, check that the instrument is mounted off-center. Multiple echoes' can interfere with the measurement. Note: It is not possible to run 2 units in the same tank.
- Ensure that pipes or ladders do not obstruct the acoustic path.
- If the instrument is mounted in a flange, ensure that a rubber o-ring is used to mechanically isolate the instrument from vibrations.

### 4. Instrument goes to default current (22mA):

- Target is out of range; ensure that the MPUL06 is pointing perpendicular at the right surface.
- Ensure that the instrument is set for the correct range; use SPAN and ZERO to set Span and Zero. Note: Do not set Span and Zero at the same distance.
- Ensure that the instrument is audibly “clicking”, if unsure feel the nose front for vibration. This should occur at a frequency of between 2 to 4 clicks per second.
- Tank level may go beyond the set range.

### 5. The instrument current level goes “wrong way” (or: the instrument indicates level the wrong way):

- Generally the instrument's current is set to drop when the target moves further away. If this is not the case or if this is not required, set the Span and Zero correctly by re-calibrating. The ZERO point is always 4mA and the SPAN point is always 20mA, it is up to the user to determine at what physical distances they are set.

**6. Instrument current occasionally jumps:**

- Target may be out of range; please ensure that the instrument is pointing perpendicular to the correct surface.
- Ensure that the instrument is set for the correct range; use SPAN and ZERO to set Span and Zero. Note: Do not set Span and Zero at the same distance.
- Check the voltage across the instrument; it must be above 17V and below 30V.
- In the case of a closed tank, check that the instrument is mounted off-center. Multiple echoes' can interfere with the measurement and mounting the instrument off-center will assist.
- Ensure that pipes or ladders do not obstruct the acoustic path.
- If instrument is mounted in a flange, ensure that a rubber o-ring is used to mechanically isolate the instrument from vibrations.
- Ensure that the shield of the instrument's cable is connected to a solid ground or earth point.

**DISTRIBUTED BY:**

Cascadia Instrumentation Inc.  
Suite 383  
7360 - 137 Street  
Surrey BC V3W 6M2  
Phone: 778-578-7956 Fax: 778-578-7986  
[www.cascadia-instrumentation.com](http://www.cascadia-instrumentation.com)

<b>rittmeyer</b>	<b>Data Sheet Hardware</b>	DG DKap Stamm-Bez. Var Ind F Sp
		<b>21.210.0067720.006.01.4.4</b>