

ULTRAFLOW® 54

DATA SHEET

- Ultrasonic flow sensor
- Compact design
- Static meter with no moving parts
- Large dynamic range
- No wear
- Exceptionally accurate
- Longevity

MID-2004/22/EC



Application

ULTRAFLOW® 54 is a static flow sensor based on the ultrasonic measuring principle. The prime area of application is as a volume flow sensor for use with thermal heat meters such as MULTICAL®. ULTRAFLOW® 54 has been designed for use in heating installations where water is used as the heat-bearing medium.

ULTRAFLOW® 54 employs micro-processor technology and ultrasonic measuring techniques. All circuits for calculating and measuring are collected on a single board, providing compact and rational design in addition to an exceptionally high level of measuring accuracy and reliability.

The flow is measured using bidirectional ultrasonic technique based on

the transit time method, with proven long-term stability and accuracy. Two ultrasonic transducers are used to send the sound signal both against and with the flow direction.

The ultrasonic signal travelling with the flow direction reaches the opposite transducer first. The time difference between the two signals can be converted to a flow velocity and thus a volume.

A multiplug, placed beneath the seal, is used during communication and calibration.

A three-wire pulse cable is used to connect ULTRAFLOW® 54 to MULTICAL®. This cable is used to supply the flow sensor from the calculator

and also to send the signal to the calculator. The signal corresponds to the flow, or more correctly, a number of pulses proportional to the water volume flowing through the meter is transmitted.

If required a Pulse Transmitter can be used to supply ULTRAFLOW® 54, e.g. if the distance between MULTICAL® and ULTRAFLOW® 54 is 10 m or more. If ULTRAFLOW® 54 is used as pulse generator for other equipment, it must be connected through a Pulse Transmitter.

The Pulse Transmitter has a built-in supply and a galvanically separated pulse outlet.



ULTRAFLOW® 54

DATA SHEET



Contents

Application	1
Approvals	3
Technical data	3
Technical data	4
Flowdata	4
Type summary	6
Dimension sketches	6
Dimension sketches	7
Dimension sketches	8
Pulse Transmitter	8
Pressure loss	9
Pressure loss graphs	9
Installation	10
Examples of installation	11
Electrical connection	12
Example of connecting ULTRAFLOW® 54 and MULTICAL®	12
Order specification	13
Accessories	14

ULTRAFLOW[®] 54

DATA SHEET



Approvals

Type approval

ULTRAFLOW[®] 54 approved in accordance with MID-2004/22/EC.

EC-Type Examination certificate: DK-0200-MI004-008.

Please contact Kamstrup A/S for further information relating to type approval and verification.

CE-marking

ULTRAFLOW[®] 54 is marked in accordance with:

- MID-directive 2004/22/EC
- LV-directive 2006/95/EC (together with the Pulse Transmitter or the Pulse Divider)
- PE-directive 97/23/EC (DN50...DN100 category I)

MID-2004/22/EC



MID designation

- Mechanical environment Class M1
- Electromagnetic environment Class E1 and E2
- Ambient temperature 5...55°C, non condensing closed location (indoor installation)

Technical data

Mechanical data

Metrological class	2 and 3
Environmental class	Complies with DS/EN 1434 class C
Ambient temperature	0...55°C
Protection class	
– Flow sensor	IP65
– Pulse Transmitter	IP54
Temperature* of medium	15...130°C
Storage temperature (empty sensor)	
– Meter without battery	-25...70°C
– Meter with battery	-25...60°C
Pressure stage	PN16, PN25 flange

* If the temperature of the medium exceeds 90°C a flange meter should be used. Additionally, MULTICAL[®] calculator or the Pulse Transmitter should be wall-mounted.

ULTRAFLOW® 54

DATA SHEET



Technical data

Electrical data

Supply voltage	3.6 V ± 0.1 V
Battery (Pulse Transmitter)	3.65 VDC, D-Cell lithium
Replacement interval	6 years @ $t_{BAT} < 30^{\circ}\text{C}$
Power supply (Pulse Transmitter)	230 VAC +15/-30%, 48...52 Hz 24 VAC ±30%
Back-up supply	Integral super-cap eliminates operational disturbances due to short-term power-cuts
Cable length, flow sensor	Max. 10 m
Cable length (Pulse Transmitter)	Depends on calculator
EMC data	Complies with DS/EN 1434 class C

Flowdata

Nom. flow q_p [m ³ /h]	Nom. diameter [mm]	Meter factor ¹⁾ [imp./l]	Dynamic range $q_i:q_p$	$q_s:q_p$	Flow @125 Hz ²⁾ [m ³ /h]	$\Delta p@q_p$ [bar]	Min. cut off [l/h]
0.6	DN15 & DN20	300	1:50 & 1:100	2:1	1.5	0.04	2
1.5	DN15 & DN20	100	1:50 & 1:100	2:1	4.5	0.22	3
2.5	DN20	60	1:50 & 1:100	2:1	7.5	0.03	5
3.5	DN25	50	1:50 & 1:100	2:1	9	0.07	7
6	DN25	25	1:50 & 1:100	2:1	18	0.2	12
10	DN40	15	1:50 & 1:100	2:1	30	0.06	20
15	DN50	10	1:50 & 1:100	2:1	45	0.14	30
25	DN65	6	1:50 & 1:100	2:1	75	0.06	50
40	DN80	5	1:50 & 1:100	2:1	90	0.05	80
60	DN100	2.5	1:50 & 1:100	2:1	180	0.03	120
100	DN100	1.5	1:50 & 1:100	2:1	300	0.07	200

¹⁾ The meter factor can be seen on the label on the side of the meter.

²⁾ Saturation flow. Max. pulse frequency 128 Hz is maintained at higher flow rates.

ULTRAFLOW® 54

DATA SHEET



Materials

Wetted parts

ULTRAFLOW® 54, q_p 0.6 og 1.5 m³/h

Housing, gland	Dezincification resistant brass
Housing, flange	Red brass, RG5
Transducers	Stainless steel, W.no. 1.4401
Gaskets	EPDM
Reflectors	Thermoplastic, PES 30% GF and stainless steel, W.no. 1.4301
Measuring pipe	Thermoplastic, PES 30% GF

ULTRAFLOW® 54, q_p 2.5 til 100 m³/h

Housing, gland	Dezincification resistant brass
Housing, flange	Red brass, RG5 or stainless steel, W.no. 1.4308 (see Order specification)
Transducers	Stainless steel, W.no. 1.4401
Gaskets	EPDM
Measuring pipe	Thermoplastic, PES 30% GF
Reflectors	Stainless steel, W.no. 1.4301

Electronic housing

Base	Thermoplastic, PBT 30% GF
Lid	Thermoplastic, PC 10% GF

Connection cable q_p 0.6 to 100 m³/h

Silicone cable (3 x 0.5^ø)

ULTRAFLOW® 54

DATA SHEET



Type summary

Nom. flow q_p [m³/h]	Size				
0.6	G $\frac{3}{4}$ x 110 mm	G1 x 130 mm			
1.5	G $\frac{3}{4}$ x 110 mm	G $\frac{3}{4}$ x 165 mm	G1 x 130 mm	G1 x 190 mm	(G1 x 165 mm)
2.5	G1 x 190 mm	DN20 x 190 mm			
3.5	G $\frac{5}{4}$ x 260 mm	DN25 x 260 mm			
6	G $\frac{5}{4}$ x 260 mm	DN25 x 260 mm			
10	G2 x 300 mm	DN40 x 300 mm			
15	DN50 x 270 mm				
25	DN65 x 300 mm				
40	DN80 x 300 mm				
60	DN100 x 360 mm				
100	DN100 x 360 mm				

(...) Country specific variants

Thread ISO 228-1

Flange EN 1092, PN25

Dimension sketches

ULTRAFLOW® 54, G $\frac{3}{4}$ and G1

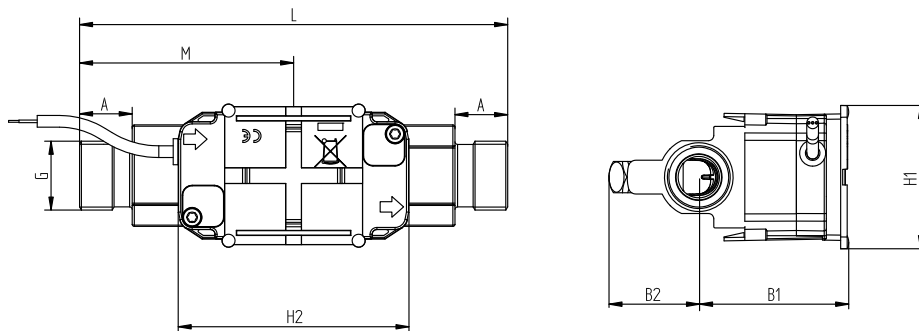

Thread ISO 228-1

Thread	L	M	H2	A	B1	B2	H1	App. weight [kg]
G $\frac{3}{4}$	110	L/2	89	10.5	58	35	55	0.8
G1	130	L/2	89	20.5	58	35	55	0.9
G $\frac{3}{4}$	165	L/2	89	20.5	58	35	55	1.2
G1	165	L/2	89	20.5	58	35	55	1.2
G1(q_p 1.5)	190	L/2	89	20.5	58	35	55	1.4
G1(q_p 2.5)	190	L/2	89	20.5	58	36	55	1.3

ULTRAFLOW® 54

DATA SHEET



Dimension sketches

ULTRAFLOW® 54, G5/4 and G2

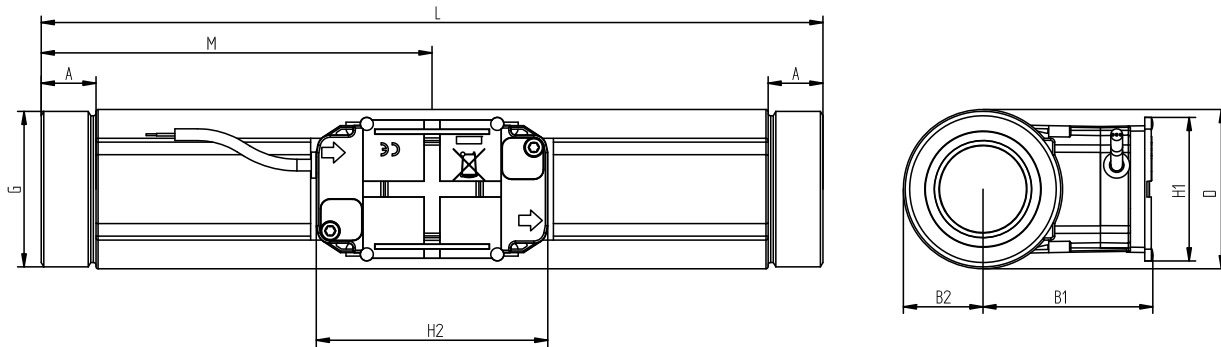

Thread ISO 228-1

Thread	L	M	H2	A	B1	B2	H1	App. weight [kg]
G5/4	260	L/2	89	17	58	22	55	2.3
G2	300	L/2	89	21	65	31	55	4.5

ULTRAFLOW® 54, DN20 to DN50

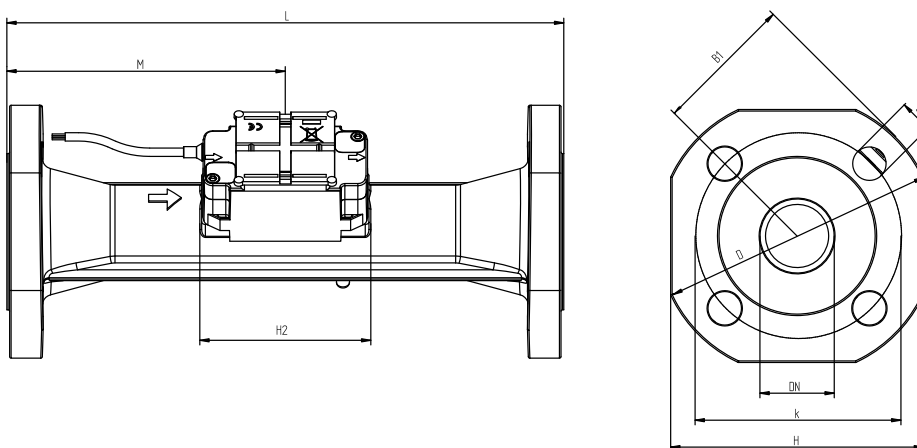

Flange EN 1092, PN25

Nom. diameter	L	M	H2	B1	D	H	k	Bolts			App. weight [kg]
								No.	Thread	d ₂	
DN20	190	L/2	89	58	105	95	75	4	M12	14	2.9
DN25	260	L/2	89	58	115	106	85	4	M12	14	5.0
DN40	300	L/2	89	<D/2	150	136	110	4	M16	18	8.3
DN50	270	155	89	<D/2	165	145	125	4	M16	18	10.1

ULTRAFLOW® 54

DATA SHEET



Dimension sketches

ULTRAFLOW® 54, DN65 to DN100

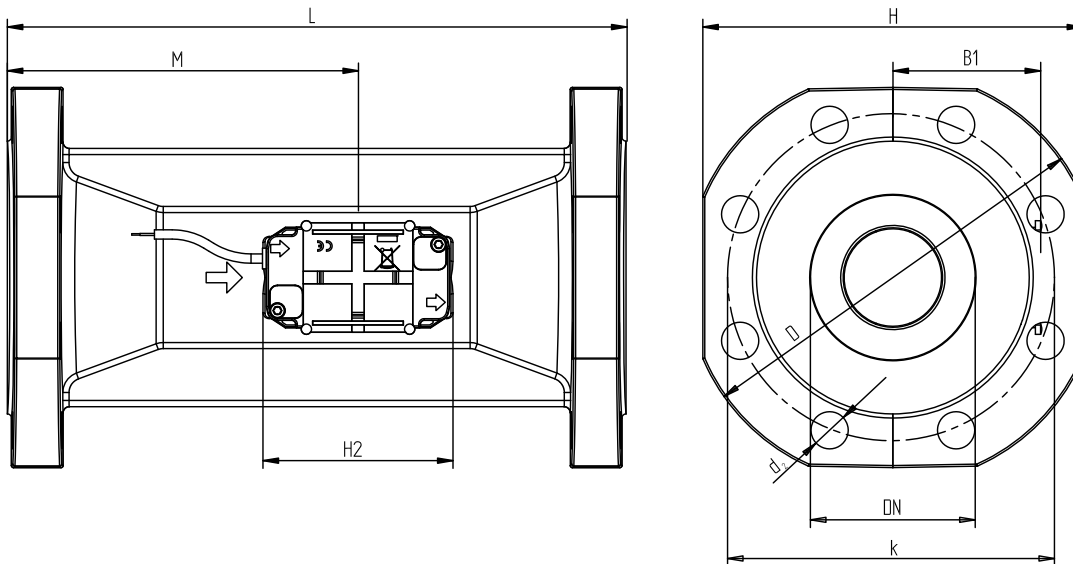

Flange EN 1092, PN25

Nom. diameter	L	M	H2	B1	D	H	k	Bolts			App. weight [kg]
								No.	Thread	d ₂	
DN65	300	170	89	<H/2	185	168	145	8	M16	18	13.2
DN80	300	170	89	<H/2	200	184	160	8	M16	18	16.8
DN100	360	210	89	<H/2	235	220	190	8	M20	22	21.7

Pulse Transmitter

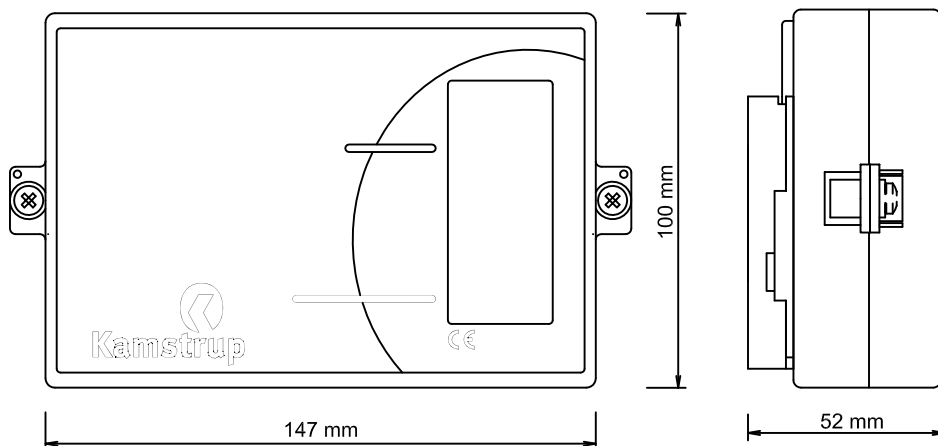

ULTRAFLOW® 54

DATA SHEET



Pressure loss

Graph	q_p [m³/h]	Nom. diameter	k_v ³⁾	Q@0.25 bar [m³/h]
A	0.6 & 1.5	DN15 & DN20	3.2	1.6
B	2.5 & 3.5 & 6	DN20 & DN25	13.4	6.7
C	10 & 15	DN40 & DN50	40	20
D	25	DN65	102	51
E	40	DN80	179	90
F	60 & 100	DN100	373	187

³⁾ $q = k_v \times \sqrt{\Delta p}$

Pressure loss graphs

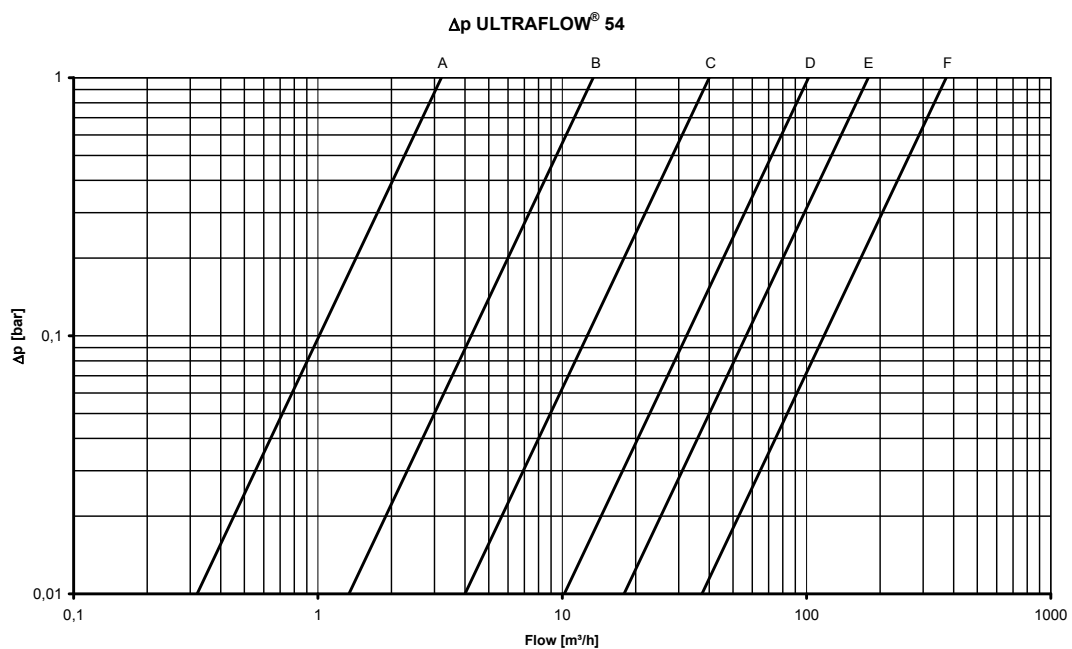

ULTRAFLOW® 54

DATA SHEET



Installation

Installation angle for ULTRAFLOW® 54 ≤DN100

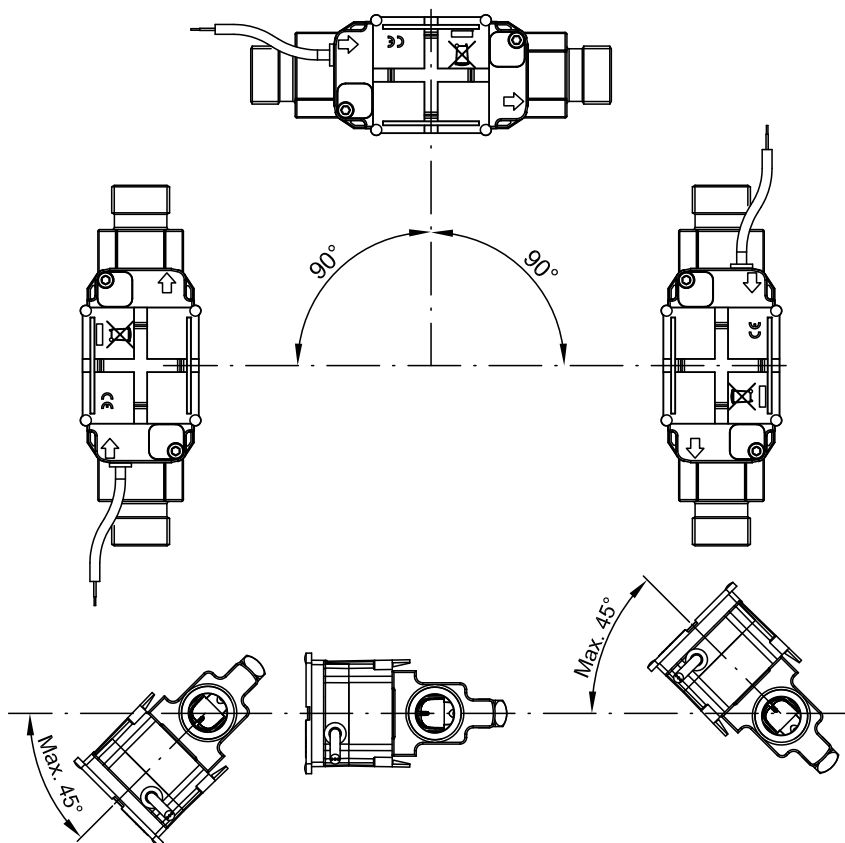

ULTRAFLOW® 54 may be installed horizontally, vertically or at an angle.

IMPORTANT!

With ULTRAFLOW® 54 ≤DN100 (100 m³/h), the electronics/ plastic case must be placed to the side (with horizontal installation).

ULTRAFLOW® 54 may be turned up to ±45° in relation to the pipe axis.

Straight inlet

ULTRAFLOW® requires neither straight inlet nor outlet to meet the Measuring Instruments Directive (MID) 2004/22/EC, OIML R75:2002 and EN 1434:2007. Only in case of heavy flow disturbances before the meter will a straight inlet section be necessary. We recommend to follow the guidelines in CEN CR 13582.

Working Pressure

In order to prevent cavitation the back pressure at ULTRAFLOW® 54 must be min. 1.5 bar at q_p and min. 2.5 bar at q_s (4.5 bar for DN80 x 350). This applies to temperatures up to approx. 80°C.

ULTRAFLOW® 54 must not be exposed to lower pressure than the ambient pressure (vacuum).

ULTRAFLOW® 54

DATA SHEET



Examples of installation

Gland meter with MULTICAL®/Pulse Transmitter fitted directly on ULTRAFLOW® 54.

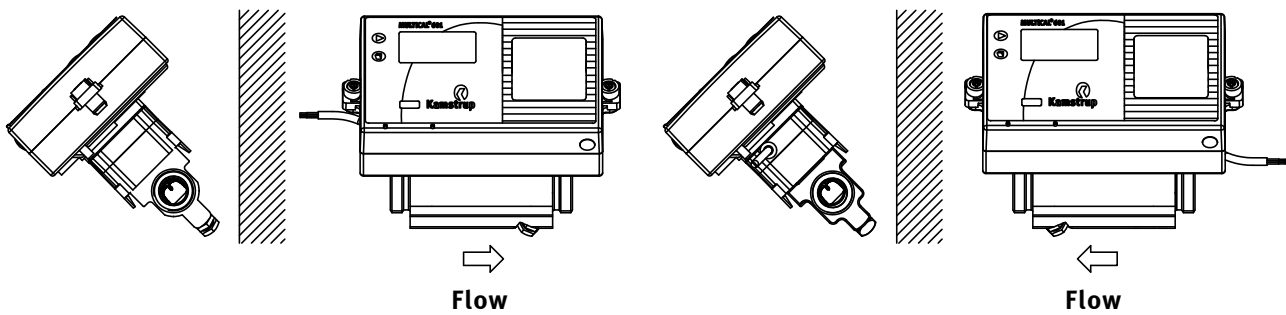

Glands and short direct sensor fitted in ULTRAFLOW® 54 (G³/₄ (R¹/₂) and G1 (R³/₄) only).

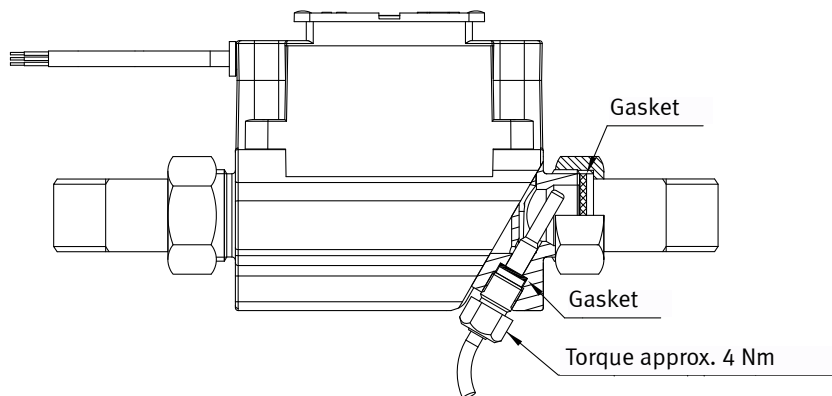

Flange meter with MULTICAL®/Pulse Transmitter fitted directly on ULTRAFLOW® 54.

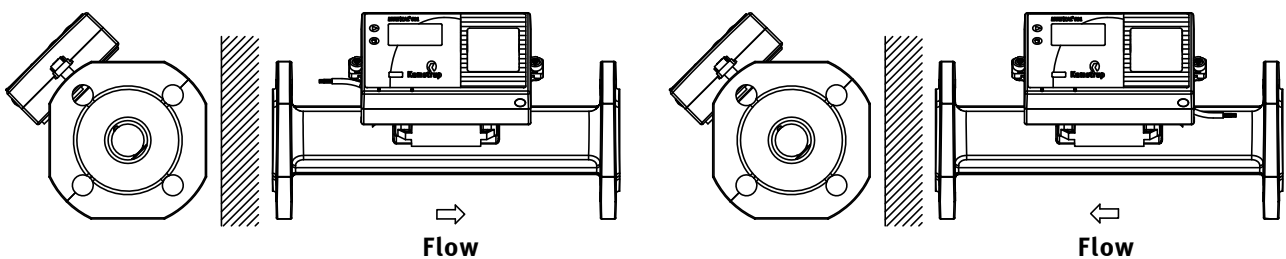

NB: For meters \geq DN100 MULTICAL® or the Pulse Transmitter **cannot** be fitted directly on the flow part.

ULTRAFLOW® 54

DATA SHEET



Electrical connection

Connecting MULTICAL® & ULTRAFLOW® 54

ULTRAFLOW® 54	->	MULTICAL®
Blue (GND)/11A	->	11
Red (supply)/9A	->	9
Yellow (signal)/10A	->	10

Connecting via Pulse Transmitter

3.65 VDC supply ⁴⁾	->	Pulse Transmitter
Red (+)	->	60
Black (-)	->	61

⁴⁾ from battery or supply module.

ULTRAFLOW® 54	->	Pulse Transmitter		->	MULTICAL®
		In	Out		
Blue (GND)/11A	->	11	11A	->	11
Red (supply)/9A	->	9	9A	->	9
Yellow (signal)/10A	->	10	10A	->	10

If long signal cables are used, please consider the installation carefully. There must be **at least 25 cm** between the signal cable and all other cables due to EMC.

Example of connecting ULTRAFLOW® 54 and MULTICAL®

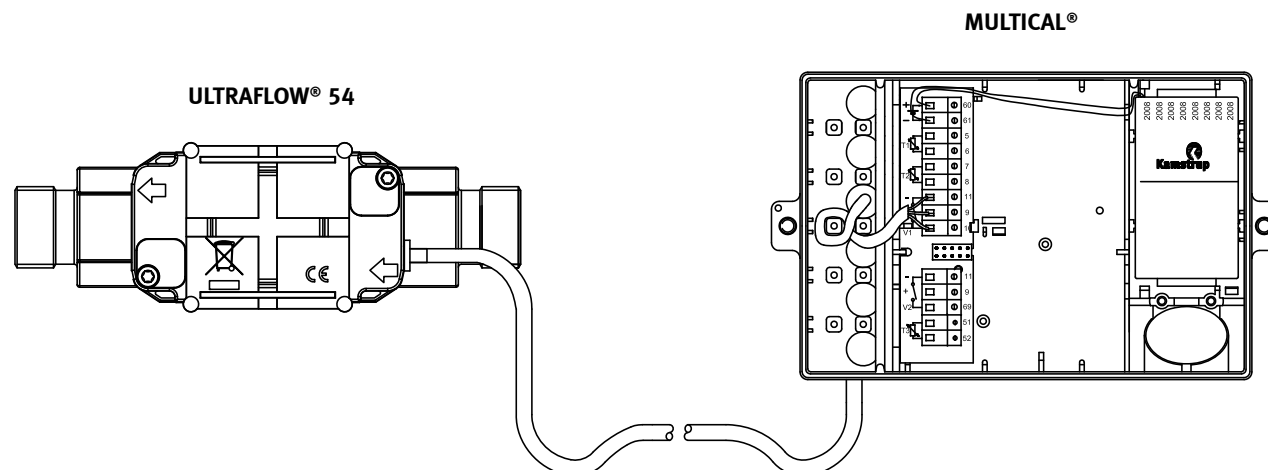

ULTRAFLOW® 54

DATA SHEET



Order specification

The list below shows type numbers for ULTRAFLOW® 54

Type number ⁵⁾	q_p [m ³ /h]	q_i [m ³ /h]	q_s [m ³ /h]	Connection	Length [mm]	Meter factor [pulses/l]	CCC (high res.)	Material
65-5- CAAA -XXX	0.6	0.006	1.2	G ³ / ₄ B (R ¹ / ₂)	110	300	416 (484)	Brass
65-5- CAAD -XXX	0.6	0.006	1.2	G1B (R ³ / ₄)	130	300	416 (484)	Brass
65-5- CDAA -XXX	1.5	0.015	3	G ³ / ₄ B (R ¹ / ₂)	110	100	419 (407)	Brass
65-5- CDAC -XXX	1.5	0.015	3	G ³ / ₄ B (R ¹ / ₂)	165	100	419 (407)	Brass
65-5- CDAD -XXX	1.5	0.015	3	G1B (R ³ / ₄)	130	100	419 (407)	Brass
(65-5- CDAE -XXX)	1.5	0.015	3	G1B (R ³ / ₄)	165	100	419 (407)	Brass
65-5- CDAF -XXX	1.5	0.015	3	G1B (R ³ / ₄)	190	100	419 (407)	Brass
65-5- CEAF -XXX	2.5	0.025	5	G1B (R ³ / ₄)	190	60	498 (-)	Brass
65-5- CEBA -XXX	2.5	0.025	5	DN20	190	60	498 (-)	Red brass
65-5- CGAG -XXX	3.5	0.035	7	G5/4B (R1)	260	50	451 (436)	Brass
65-5- CGBB -XXX	3.5	0.035	7	DN25	260	50	451 (436)	Red brass
65-5- CGCB -XXX	3.5	0.035	7	DN25	260	50	451 (436)	Stainless steel
65-5- CHAG -XXX	6	0.06	12	G5/4B (R1)	260	25	437 (438)	Brass
65-5- CHBB -XXX	6	0.06	12	DN25	260	25	437 (438)	Red brass
65-5- CHCB -XXX	6	0.06	12	DN25	260	25	437 (438)	Stainless steel
65-5- CJAJ -XXX	10	0.1	20	G2B (R1 ¹ / ₂)	300	15	478 (483)	Brass
65-5- CJBD -XXX	10	0.1	20	DN40	300	15	478 (483)	Red brass
65-5- CJCD -XXX	10	0.1	20	DN40	300	15	478 (483)	Stainless steel
65-5- CKCE -XXX	15	0.15	30	DN50	270	10	420 (485)	Stainless steel
65-5- CLCG -XXX	25	0.25	50	DN65	300	6	479 (-)	Stainless steel
65-5- CMCH -XXX	40	0.4	80	DN80	300	5	458 (486)	Stainless steel
65-5- FAFL -XXX	60	0.6	120	DN100	360	2.5	470 (487)	Stainless steel
65-5- FBCL -XXX	100	1	200	DN100	360	1.5	480 (488)	Stainless steel

⁵⁾ XXX-code pertaining to final assembly, approvals etc. is determined by Kamstrup A/S. Some variants may not be included in national approvals.

(...) Country specific variants

ULTRAFLOW® 54 is as standard supplied with 2.5 m cable, but can also be supplied with 5 or 10 m cable.

Pulse Transmitter – type No. 66-99-603

The Pulse Transmitter is supplied with built-in supply for ULTRAFLOW® 54. Battery, 24 VAC and 230 VAC supply are available. Please state the required supply type when ordering.

ULTRAFLOW® 54

DATA SHEET



Accessories

Glands including gaskets (PN16)

Size	Nipple	Union	Type No.	2 pcs.
DN15	R½	G¾	-	6561-323
DN20	R¾	G1	-	6561-324
DN25	R1	G5/4	6561-325	-
DN32	R5/4	G1½	6561-314	-
DN40	R1½	G2	6561-315	-

Gaskets for flange meters (PN25)

Size	Type No.
DN20	2210-147
DN25	2210-133
DN40	2210-132
DN50	2210-099
DN65	2210-141
DN80	2210-140
DN100	1150-142

Gaskets for glands

Size (union)	Type No.
G¾	2210-061
G1	2210-062
G5/4	2210-063
G½	2210-064
G2	2210-065